



iHP5 Series Heat Pump

Up to 15.2 SEER2

Cooling capacity: 18 - 60 kBtu/h



Contents:

1 NOMENCLATURE.....	2
2 SPECIFICATIONS.....	3
3 DIMENSIONS.....	5
4 WIRING DIAGRAMS.....	6



Standard Features:

- R410A chlorine-free refrigerant.
- Energy-efficient compressor.
- Internally protection against high temperature motor overload conditions.
- High quality condenser with inner-groove copper tube and aluminum fin.
- Service valves with sweat connections and easy-access gauge ports.
- Factory-installed high pressure switch and low pressure switch.
- AHRI certified and ETL listed.
- Optional drier filter as accessory.

Cabinet Features:

- Unique sound control top design.
- Compact design, easy installation and transportation.
- Powder-painted galvanized steel cabinet.
- Wire fan discharge grille.
- Steel louver coil guard

1 Nomenclature

A	H	P	5	-	0	1	8	-	E	1000	A
1	2	3	4		5	6	7		8	9-12	13

Legend		
No.	Code	Remarks
1	A	Brand: iAir
2-3	HP	Heat Pump
4	5	Seer Rating
5	0	Not Currently Used
6-7	18	Capacity: 18: 18 kBtu/h; 24: 24 kBtu/h; 30: 30 kBtu/h; 36: 36 kBtu/h; 42: 42 kBtu/h; 48: 48 kBtu/h; 60: 60 kBtu/h; 61: 60 kBtu/h;
8	E	Power supply type: E: 1-Phase; F: 3- Phase
9-12		Not Currently Used
13	A	Revision

2 Specifications

	AHP5-018-E1000A	AHP5-024-E1000A	AHP5-030-E1000A	AHP5-036-E1000A
NOMINAL CAPACITY				
Cooling (BTU/h)	18,000	24,000	30,000	36,000
Heating (BTU/h)	18,000	24,000	30,000	36,000
ELECTRICAL DATA				
Voltage / Phase (60 Hz)	208/230 / 1	208/230 / 1	208/230 / 1	208/230 / 1
Min. / Max. Voltage	187/253	187/253	187/253	187/253
MCA	13.0	15.5	17.2	23.0
MOP	20	24	30	40
COMPRESSOR				
Type	Scroll	Scroll	Scroll	Scroll
Stage	Single	Single	Single	Single
RLA	8	8	8	8
LRA	48	52	72	75
Crankcase Heater	Yes	Yes	Yes	Yes
CONDENSER COIL				
Throttle Type	Tube & Fin	Tube & Fin	Tube & Fin	Tube & Fin
Tube Size(O.D)	3/16	3/16	3/16	3/16
FAN MOTOR				
Motor Type	ECM	ECM	ECM	ECM
Horsepower (HP)	1-1/6	1-1/6	1-1/6	1-1/3
Full Load Amps (FLA)	1.6	1.6	1.6	2.2
REFRIGERATION SYSTEM				
Liquid Valve Size (O.D.)	3/8	3/8	3/8	3/8
Suction Valve Size (O.D.)	3/4	3/4	3/4	3/4
Liquid Line Size ("O.D.)	3/8	3/8	3/8	3/8
Suction Line Size ("O.D.)	3/4	3/4	3/4	3/4
Refrigerant Charge (lbs. - oz.)	5 LBS.-4 OZ	6 LBS.-7 OZ	6 LBS.-7 OZ	7 LBS.-2 OZ
Superheat(°F)	9°F	9°F	9°F	9°F
OPERATION RANGE				
Cooling(°F)	55-115	55-115	55-115	55-115
Heating(°F)	5-86	5-86	5-86	5-86
SOUND POWER (DB)	72	74	73	73

Specifications

	AHP5-042-E1000A	AHP5-048-E1000A	AHP5-060-E1000A	AHP5-061-E1000A
NOMINAL CAPACITY				
Cooling (BTU/h)	42,000	48,000	60,000	60,000
Heating (BTU/h)	42,000	48,000	60,000	60,000
ELECTRICAL DATA				
Voltage / Phase (60 Hz)	208/230 / 1	208/230 / 1	208/230 / 1	208/230 / 1
Min. / Max. Voltage	187/253	187/253	187/253	187/253
MCA	26.9	29.6	34.6	38.9
MOP	50	50	60	60
COMPRESSOR				
Type	Scroll	Scroll	Scroll	Scroll
Stage	Single	Single	Single	Two-stage
RLA	8	8	8	29.3
LRA	112.3	94	127.1	118
Crankcase Heater	Yes	Yes	Yes	Yes
CONDENSER COIL				
Type	Tube & Fin	Tube & Fin	Tube & Fin	Tube & Fin
Tube Size(O.D)	3/16	3/16	9/32	9/32
FAN MOTOR				
Motor Type	ECM	ECM	ECM	ECM
Horsepower (HP)	1-1/3	1-1/3	1-1/3	1-1/3
Full Load Amps (FLA)	2.2	2.2	2.2	2.2
REFRIGERATION SYSTEM				
Liquid Valve Size (O.D.)	3/8	3/8	3/8	3/8
Suction Valve Size (O.D.)	7/8	7/8	7/8	7/8
Liquid Line Size ("O.D.)	3/8	3/8	3/8	3/8
Suction Line Size ("O.D.)	7/8	11/8	11/8	11/8
Refrigerant Charge (lbs. - oz.)	8 LBS.-7 OZ	8 LBS.-7 OZ	11 LBS.-5 OZ	10 LBS.-14 OZ
Superheat(°F)	9°F	9°F	9°F	9°F
OPERATION RANGE				
Cooling(°F)	55-115	55-115	55-115	55-115
Heating(°F)	5-86	5-86	5-86	5-86
SOUND POWER (DB)	76	76	78	79

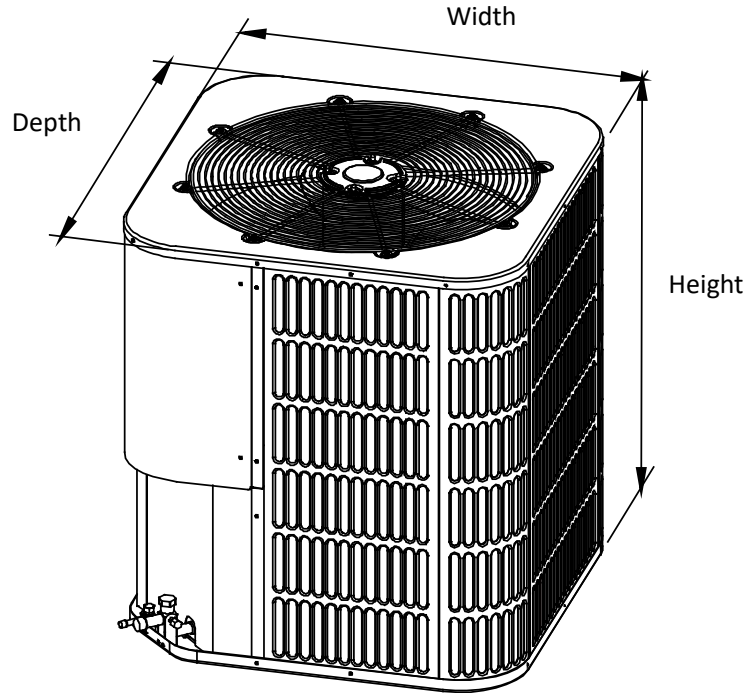
3 Dimensions

	AHP5-018-E1000A	AHP5-024-E1000A	AHP5-030-E1000A	AHP5-036-E1000A
UNIT DIMENSION AND WEIGHTS				
Height (in.)	24-15/16	24-15/16	24-15/16	33-3/16
Width (in.)	23-5/8	28	28	28
Depth (in.)	23-5/8	28	28	28
Weight (lbs.)	137	154	157	179

	AHP5-042-E1000A	AHP5-048-E1000A	AHP5-060-E1000A	AHP5-061-E1000A
UNIT DIMENSION AND WEIGHTS				
Height (in.)	33-3/16	33-3/16	33-3/16	33-3/16
Width (in.)	29-1/8	29-1/8	29-1/8	29-1/8
Depth (in.)	29-1/8	29-1/8	29-1/8	29-1/8
Weight (lbs.)	198	201	218	227

4 Wiring Diagrams

AHP5-018-E1000A; AHP5-024-E1000A; AHP5-030-E1000A; AHP5-036-E1000A;
 AHP5-042-E1000A; AHP5-048-E1000A; AHP5-060-E1000A;

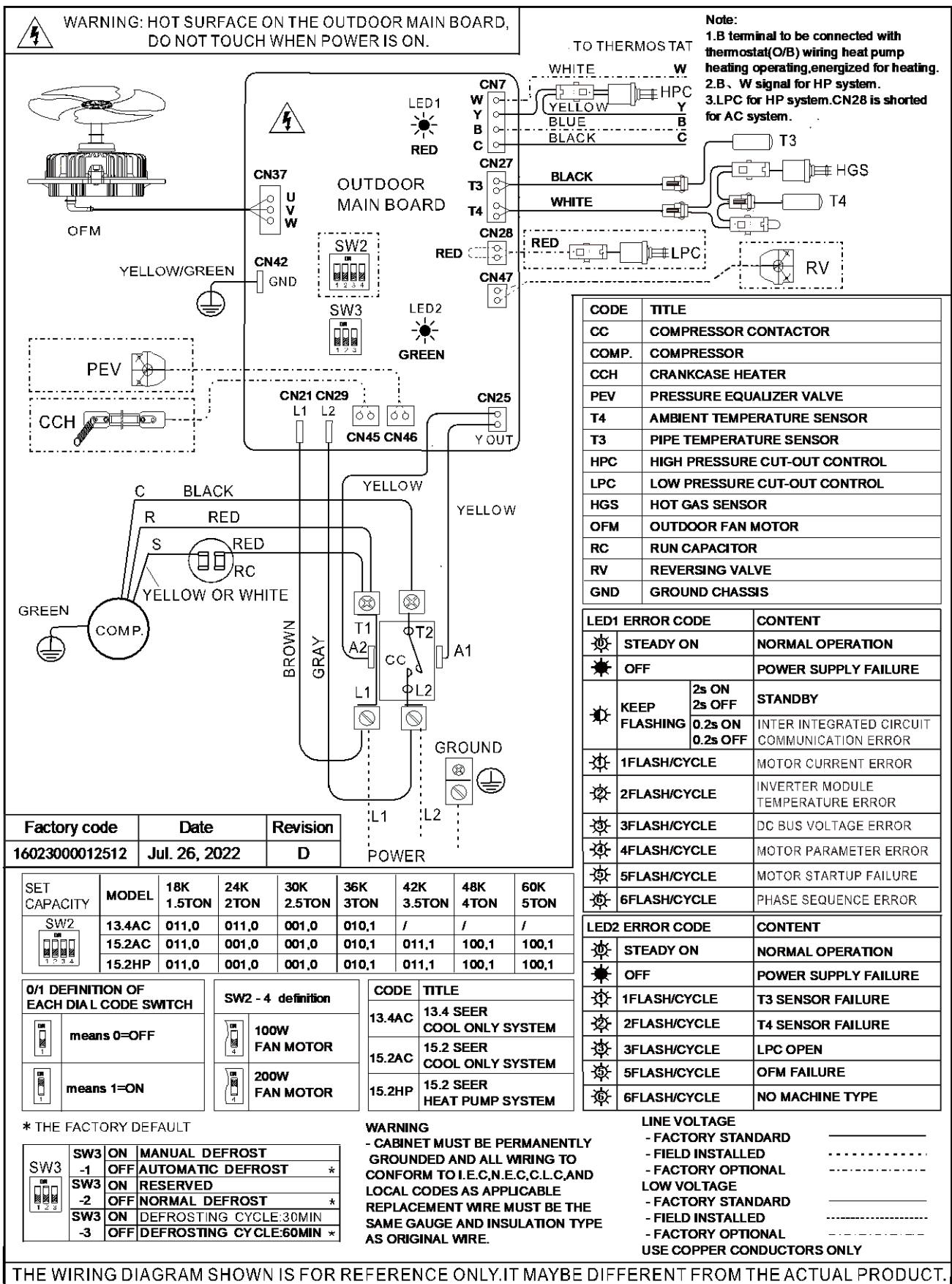

Wiring Diagrams

AHP5-061-E1000A;

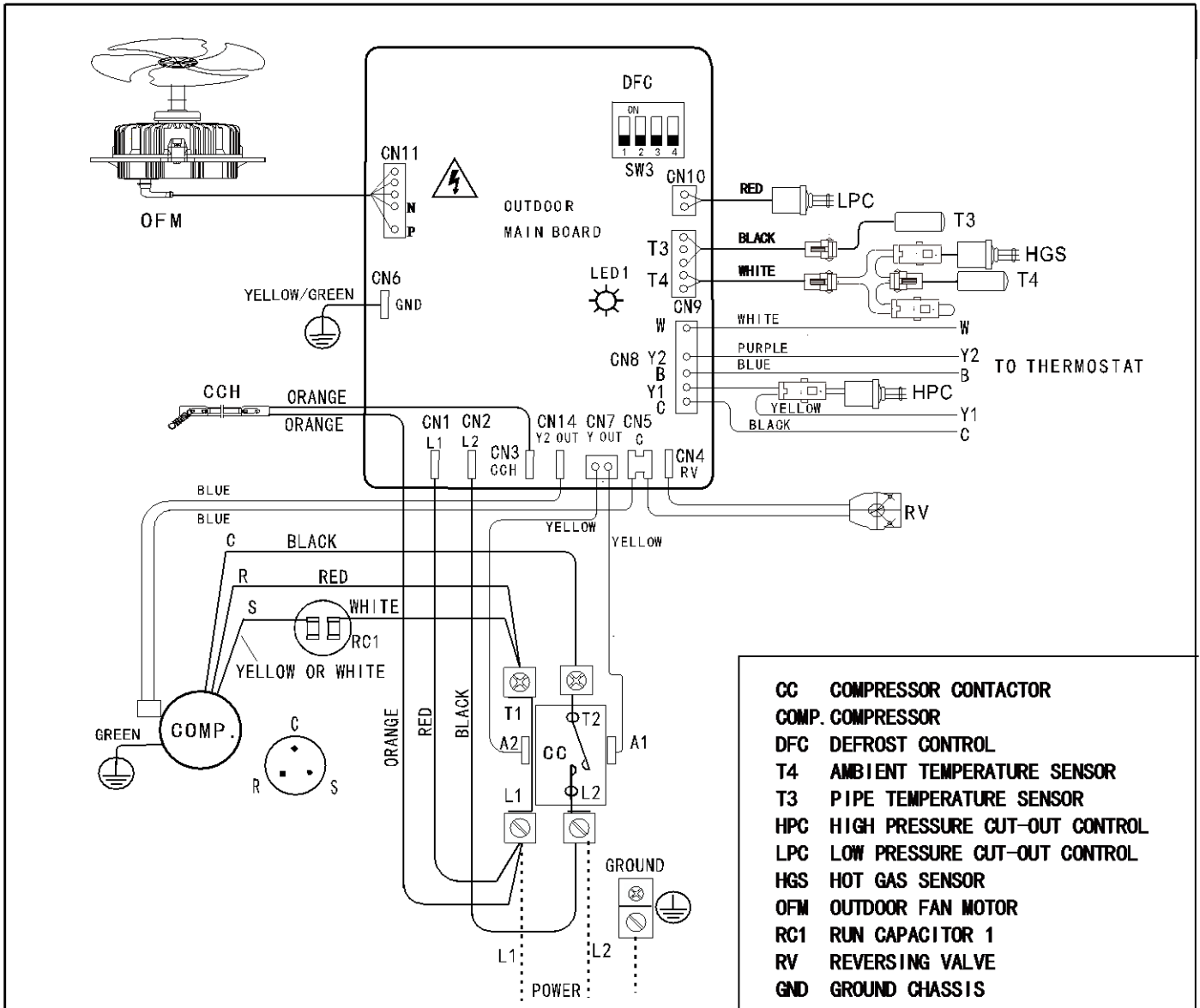

- CC COMPRESSOR CONTACTOR
- COMP. COMPRESSOR
- DFC DEFROST CONTROL
- T4 AMBIENT TEMPERATURE SENSOR
- T3 PIPE TEMPERATURE SENSOR
- HPC HIGH PRESSURE CUT-OUT CONTROL
- LPC LOW PRESSURE CUT-OUT CONTROL
- HGS HOT GAS SENSOR
- OFM OUTDOOR FAN MOTOR
- RC1 RUN CAPACITOR 1
- RV REVERSING VALVE
- GND GROUND CHASSIS

*THE FACTORY DEFAULT

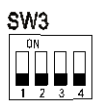

SW3-1	ON	MANUAL DEFROST
	OFF	AUTOMATIC DEFROST *
SW3-2	ON	RESERVED
	OFF	NORMAL DEFROST *
SW3-3	ON	DEFROSTING CYCLE: 30MIN *
	OFF	DEFROSTING CYCLE: 60MIN *
SW3-4	ON	RESERVED
	OFF	NORMAL *

	STEADY ON	NORMAL OPERATION
	OFF	DFC FAILURE
	1FLASH	T3 SENSOR FAILURE
	2FLASH	T4 SENSOR FAILURE
	3FLASH	LPC OPEN
	5FLASH	OFM FAILURE

- LINE VOLTAGE
- FACTORY STANDARD _____
 - FIELD INSTALLED*
 - FACTORY OPTIONAL - - - - -

- LOW VOLTAGE
- FACTORY STANDARD _____
 - FIELD INSTALLED*
 - FACTORY OPTIONAL - - - - -

USE COPPER CONDUCTORS ONLY

WARNING

- CABINET MUST BE PERMANENTLY GROUNDED AND ALL WIRING TO CONFORM TO I. E. C, N. E. C, C. L. C, AND LOCAL CODES AS APPLICABLE
- REPLACEMENT WIRE MUST BE THE SAME GAUGE AND INSULATION TYPE AS ORIGINAL WIRE.

Add.: 8105 Anderson Rd, Tampa, FL 33634

833-305-4247

iair-usa.com



Note: Product specifications change from time to time as product improvements and developments are released and may vary from those in this document.